



XMD

Differential Pressure Transmitter for Process Industry with HART®-Communication

accuracy according to IEC 60770:
0.075 % span

Nominal pressure

from 60 mbar up to 20 bar

Output signals

2-wire: 4 ... 20 mA / HART®
others on request

Special characteristics

- ▶ static over pressure 400 bar
- ▶ two chamber aluminium die cast case
- ▶ HART®-communication
- ▶ output signal: linear or square root extraction
- ▶ explosion protection, intrinsic safety Exia
- ▶ flameproof enclosure Exd





Optional versions

- ▶ SIL 2 according to IEC 61508
- ▶ with integrated display and operating module
- ▶ preparation for assembly of process connections

The intelligent XMD transmitter is designed for measurement of differential pressure in industrial processes of all production branches. It has an excellent long-term stability.

With the use of the square root output signal can be the steam and gas flow in orifice plates and speed probes measured.

Preferred areas of use are

-  Oil and gas industry
-  Chemical and petrochemical industry
-  Energy Industry
-  Food and beverage
-  Paper Industry



Sensor type	B	C	D	E
Differential pressure range dp	60 mbar	400 mbar	2.5 bar	20 bar
Setting limits (offset and span in this range freely adjustable)	-60 ... 60 mbar	-400 ... 400 mbar	-2.5 ... 2.5 bar	-20 ... 20 bar
Lowest permissible span	2 mbar	4 mbar	25 mbar	200 mbar
Permissible static pressure optional	160 bar -	160 bar 400 bar	160 bar 400 bar	160 bar 400 bar
Rangeability TD (with respect to the differential pressure range dp)	30:1	100:1	100:1	100:1

Output signal / Supply	
2-wire: 4 ... 20 mA with explosion protection	standard: intrinsic safety (ia) with HART®-communication options: flameproof equipment (d) with HART®-communication SIL2 / intrinsic safety (ia) with HART®-communication SIL2 / flameproof equipment (d) with HART®-communication $V_S = 12 \dots 28 \text{ V}_{DC}$ $V_S = 13 \dots 28 \text{ V}_{DC}$ $V_S = 12 \dots 28 \text{ V}_{DC}$ $V_S = 13 \dots 28 \text{ V}_{DC}$
Performance	
Accuracy	turn-down $\leq 10:1$: $\leq \pm 0.075 \%$ span turn-down $> 10:1$: $\leq \pm [0.0075 \times \text{turn-down}] \%$ span with turn-down = nominal pressure range / adjusted range
Influence supply	$\leq 0.001 \%$ span / 10 V
Influence static pressure	type B: $\pm [0.06 \text{ mbar} + 0.075 \%$ of the adjusted range] / 160 bar type C: $\pm [0.2 \text{ mbar} + 0.05 \%$ of the adjusted range] / 160 bar type D: $\pm [1.25 \text{ mbar} + 0.05 \%$ of the adjusted range] / 160 bar type E: $\pm [10 \text{ mbar} + 0.05 \%$ of the adjusted range] / 160 bar
Influence installation position	max. 400 Pa (can be compensated by zero-point correction)
Long term stability	type B: $\leq \pm (0.2 \%$ x differential pressure range dp) / year at reference conditions type C - E: $\leq \pm (0.1 \%$ x differential pressure range dp) / year at reference conditions
Permissible load	without LC-display: $R_{max} = [(V_S - 12 \text{ V}) / 0.023 \text{ A}] \Omega$ with LC-display: $R_{max} = [(V_S - 15 \text{ V}) / 0.023 \text{ A}] \Omega$ HART®-communication: $R = 230 \Omega \dots 600 \Omega$
Response time	type B: approx. 0.4 sec type C: approx. 0.2 sec type D: approx. 0.2 sec type E: approx. 0.1 sec
Damping	electronic: 0.1 ... 60 sec plus response time
Thermal effects (Offset and Span)	
Temperature range -20 ... +65°C	type B: $\pm [0.30 \times \text{turn-down} + 0.20] \%$ of the adjusted range] type C - E: $\pm [0.20 \times \text{turn-down} + 0.10] \%$ of the adjusted range]
Temperature range -40 ... -20°C and +65 ... +100°C	type B: $\pm [0.30 \times \text{turn-down} + 0.20] \%$ of the adjusted range] type C - E: $\pm [0.20 \times \text{turn-down} + 0.10] \%$ of the adjusted range]
Permissible temperatures	
Environment/storage	without display: -40 ... 85 °C with display: -20 ... 65 °C (85°C without function)
Media wetted parts	silicone oil: -40 ... 100 °C (information: +125 °C short time, max. 30 min.) fluorolube oil: -40 ... 100 °C (information: +125 °C short time, max. 30 min.)
Electrical protection	
Short-circuit protection	permanent
Reverse polarity protection	no damage, but also no function
Electromagnetic compatibility	emission and immunity according to EN 61326
Mechanical stability	
Vibration	5 g RMS (25 ... 2000 Hz) according to DIN EN 60068-2-6
Shock	100 g / 1 msec according to DIN EN 60068-2-27
Materials	
Pressure port	stainless steel 1.4401 (316)
Housing	aluminium die cast, powder-coated
Viewing glass	laminated safety glass
Seals (media wetted)	FKM / EPDM
Diaphragm	standard: stainless steel 1.4435 (316 L) option: Hastelloy® C-276 (2.4819)
Media wetted parts	pressure port, seals, diaphragm
Filling fluids	silicon oil
Explosion protection	
Approval AX2-XMD (with SIL2)	intrinsic safety IBExU 05 ATEX 1106 X (with SIL2: IBExU 05 ATEX1105 X) zone 0/1: II 1/2G Ex ia IIB T4 Ga/Gb zone 20: II 1D Ex ia IIIC T85 °C Da
Safety technical maximum values for intrinsically safe version	$U_i = 28 \text{ V}$, $I_i = 98 \text{ mA}$, $P_i = 680 \text{ mW}$, $C_i = 0 \text{ nF}$, $L_i = 0 \text{ }\mu\text{H}$, $C_{GND} = 33 \text{ nF}$

Approval AX7-XMD (with SIL2)	flameproof enclosure IBExU 12 ATEX 1045 X (with SIL2: IBExU 12 ATEX1073 X) zone 1: II 2G Ex db IIC T5 Gb
Permissible temperatures for environment	in zone 0: -20 ... 60 °C with p_{atm} 0.8 bar up to 1.1 bar in zone 1 or higher: intrinsic safety: -40 ... 70 °C / flameproof enclosure: -20 ... 70 °C
Miscellaneous	
Option SIL 2 version	according to IEC 61508
Display (optionally)	LC display, visible range 32.5 x 22.5 mm; 5-digit 7-segment main display, digit height 8 mm, range of indication ± 9999 ; 8-digit 14-segment additional display, digit height 5 mm; 52-segment bargraph; accuracy 0.1% \pm 1 digit
Ingress protection	IP 67
Installation position	any
Weight	min. 3500 g
Current consumption	approx. 21 mA
Operational life	> 100 x 10 ⁶ cycles
CE-conformity	EMC Directive: 2014/30/EU
ATEX Directive	2014/34/EU
Connections	
Electrical connection	terminal clamps in clamping chamber with cable gland M20x1.5 (for cable- \varnothing 5 up to 14 mm)
For mechanical connection	internal threads 7/16-20 UNF (connecting screws are not part of delivery)

Wiring diagram

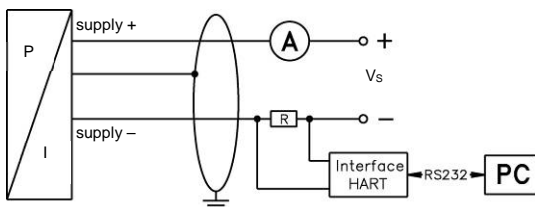

Pin configuration

Electrical connection	terminal clamps (clamp section 2.5 mm ²)
Supply + (Vs+)	+
Supply - (Vs-)	-
Test +	TEST+
COM / Test -	COM/TEST-
COM	COM
Ground	\perp

Dimensions (in mm)²

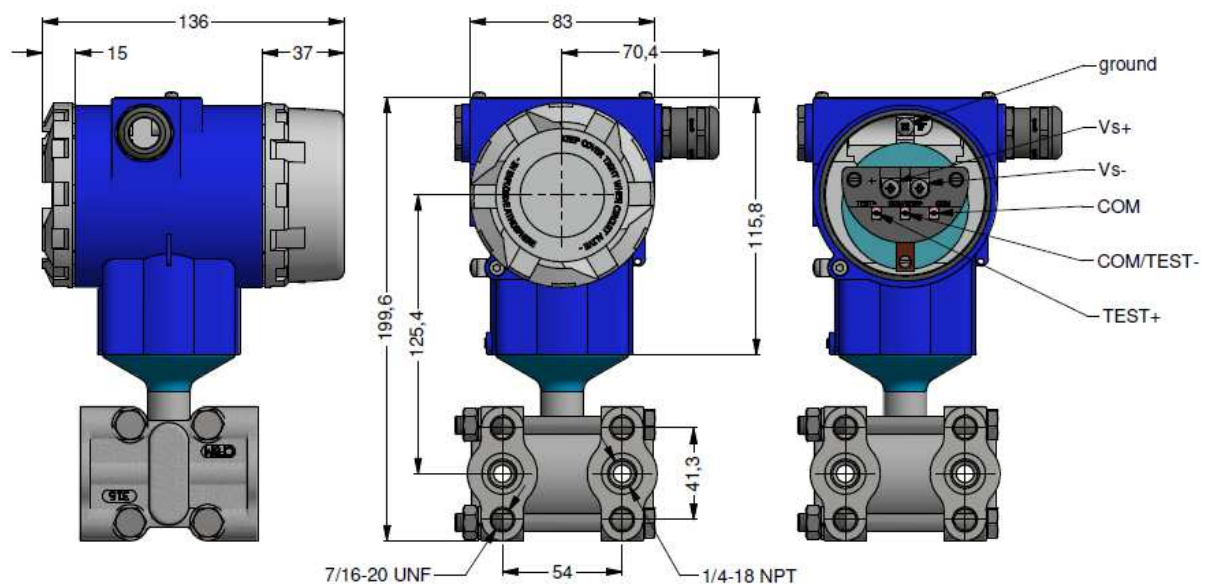

* without display and operating module marked dimensions decrease by 22 mm

² aluminium die cast case is horizontally rotatable

HART® is a registered trade mark of HART Communication Foundation; Hastelloy® is a brand name of Haynes International Inc.
Windows® is a registered trade mark of Microsoft Corporation

Accessories

Universal holder	
Weight	550 g
Material	black steel
Ordering code	5029224

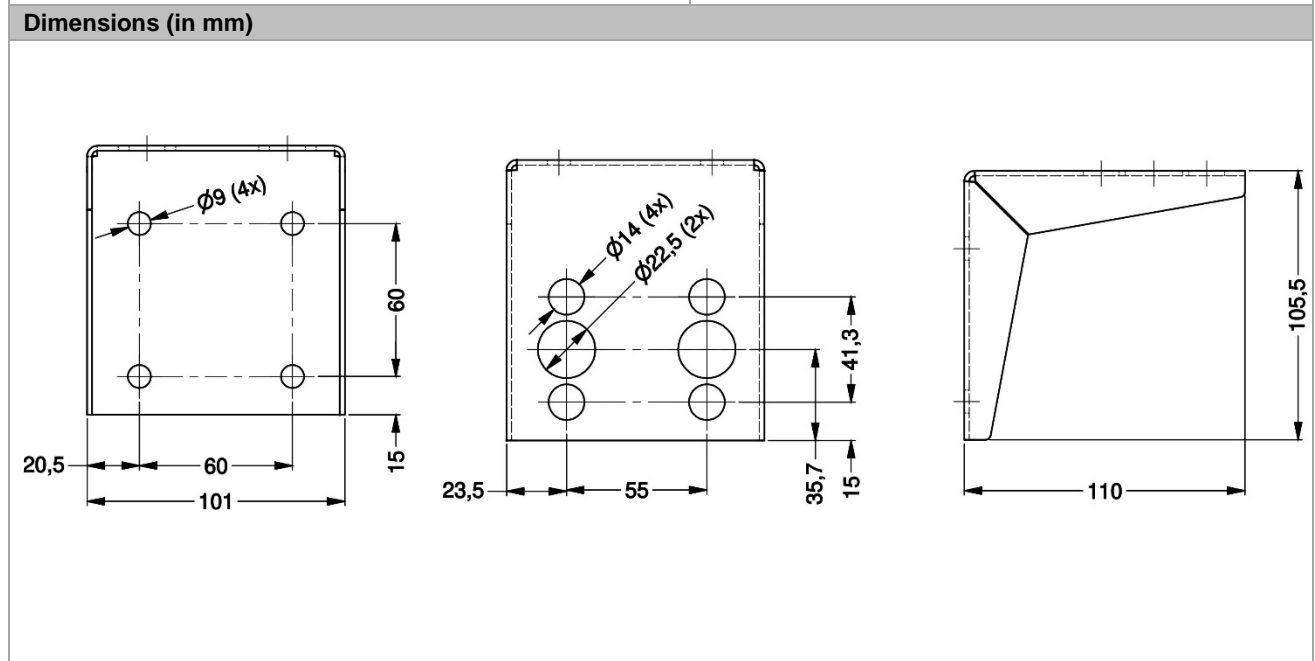

XMD

6.4.2021

XMD

□ □ □ - □ □ □ - □ - □ □ - □ - □ □ □ - □ □ □ - □ - □ - □ - □ □ □

Pressure										
Differential pressure	3	4	0							
Input										
0 ... 60 mbar	0	6	0	0						
0 ... 400 mbar	4	0	0	0						
0 ... 2,5 bar	2	5	0	1						
0 ... 20 bar	2	0	0	2						
-60 ... 60 mbar	S	0	6	0						
-400 ... 400 mbar	S	4	0	0						
-2,5 ... 2,5 bar	S	2	5	2						
Customer	9	9	9	9						
Maximum static pressure										
160 bar					1					
400 bar (P _N ≥ 0.4 bar)					4					
Display										
Without local indicator					A	N				
With LC multiple function indicator					A	0				
Output signal										
HART® - 4 ... 20 mA / 2-wire									H	
HART® - Intrinsic safety Ex ia 4 ... 20 mA / 2-wire									I	
HART® - Flameproof equipment Ex d 4 ... 20 mA / 2-wire									G	
SIL2, HART® - 4 ... 20 mA / 2-wire									HS	
SIL2, HART® - Intrinsic safety 4 ... 20 mA / 2-wire									IS	
SIL2, HART® - Flameproof equipment 4 ... 20 mA / 2-wire									GS	
Customer									9	
Accuracy										
0,1 %									1	
0,1 % including Calibration Certificate									P	
0,075 %									17	
0,075 % including Calibration Certificate									P1	
Electrical connection										
Terminal clamp									A	K 0
Mechanical connection										
1/4" NPT internal thread									N	5 6
Customer									9	9 9
Diaphragm material										
Stainless steel 1.4435 (316L)									1	
Hastelloy® C-276 (2.4819)									H	
Customer									9	
Seals										
Viton (FKM)									1	
EPDM									3	
PTFE									4	
Standard										
Standard									1	
Special version										
Standard									0	0 0
Square root output signal - active									1	9 0

Optional accessories	
Electrical connection Ex ia (standard)	
Blind flange Ex ia (M20x1,5 thread)	1001871
Cable gland Ex ia (M20x1,5 thread)	1001460
Electrical connection Ex D (standard)	
Blind flange Ex D (M20x1,5 thread)	1001438
Cable gland Ex D (M20x1,5 thread)	1001870
Process connection	
Blinding plug 1/4" NPT (external thread)	5002322
Blinding plug with venting 1/4" NPT (external thread)	1003217
Screw 7/16" UNF (4 pcs needed)	1004639
Diaphragm Seal	
The price of the mechanical connection (see below)	
Capillary tube (price for 1 m)	
Capillary tube armoured (price for 1 m)	
Flange with integral extended diaphragm	
The price of the mechanical connection (see below)	
Extension length up to 100 mm	

Extension length between 100 - 200 mm

Mechanical connection

Flange DN 25/PN 40 DIN 2501 (without seals)

Flange DN 40/PN 40 DIN 2501 (without seals)

Flange DN 50/PN 40 DIN 2501 (without seals)

Flange DN 80/PN 16 DIN 2501 (without seals)

Flange DN 100/PN 16 DIN 2501 (without seals)

Customer

Mounting bracket

Universal holder for XMD

5029224

Factory Calibration Certificate

Table of measured values - printed on Warranty Certificate

0,-...without additional charge

On request...in accordance with the producer

!!! When you make an order it is necessary to fill the questionnaire for transmitters with separators!!!

Surcharges for calibration are not subject to any discounts. Subject to change. □

This document contains the specification for ordering the product;

detailed technical parameters of the product and its possible variants are given in the data sheet.